

REVISIONS			
REV	DESCRIPTION	DATE	APPROVED

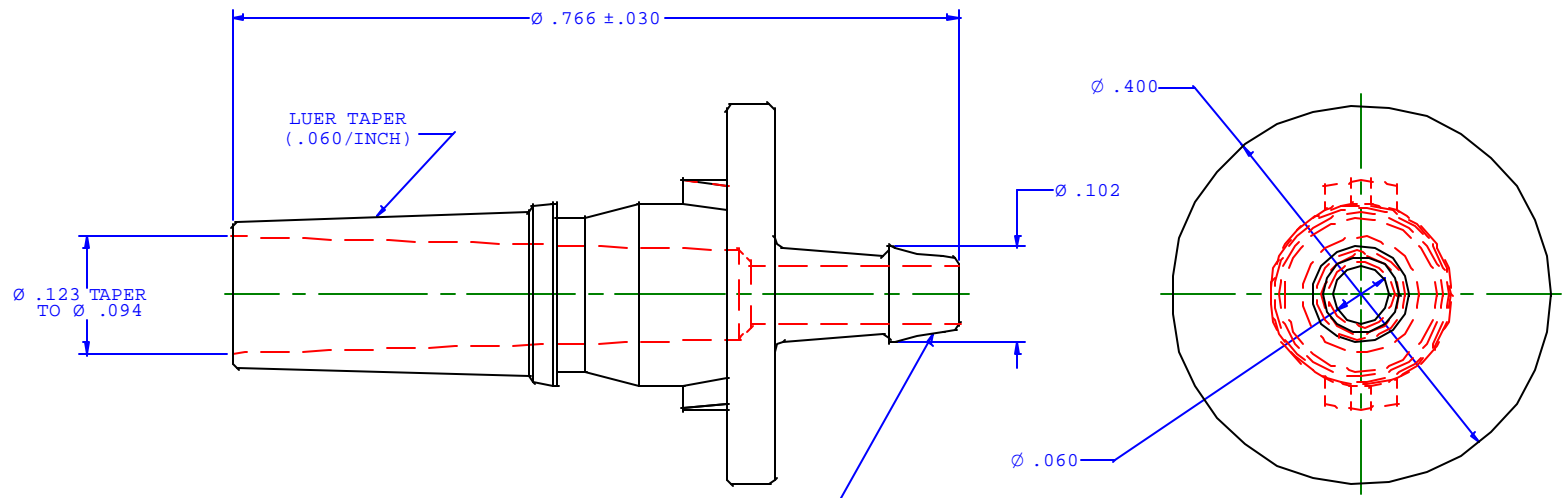

INSTRUMENT QUALITY PART.  
NO PARTING LINE ALLOWED ON  
THIS CRITICAL SURFACE.

UNLESS OTHERWISE SPECIFIED DIMENSIONS ARE IN INCHES TOLERANCES ARE:		<b>VALUE PLASTICS, INC.</b>	
FRACTIONS ±	DECIMALS .XX ±.01 .XXX ±.005	ANGULAR ±1°	PART NUMBER: MLSL004
DO NOT SCALE DRAWING		DESCRIPTION: Male Luer to 500 Series Barb, 1/16" (1.5 mm) ID Tubing (May be used with separate Stationary lock ring: FSLLR)	
DRAWN BY: SUE CORAM	SCALE: NTS	DRAWING NUMBER:	REV.
DATE: 08/20/97	© 1997 VALUE PLASTICS, INC.		SHEET:

**FOR REFERENCE ONLY**